

TREATED TIMBER BOX CULVERT DETAILS

NOT TO SCALE

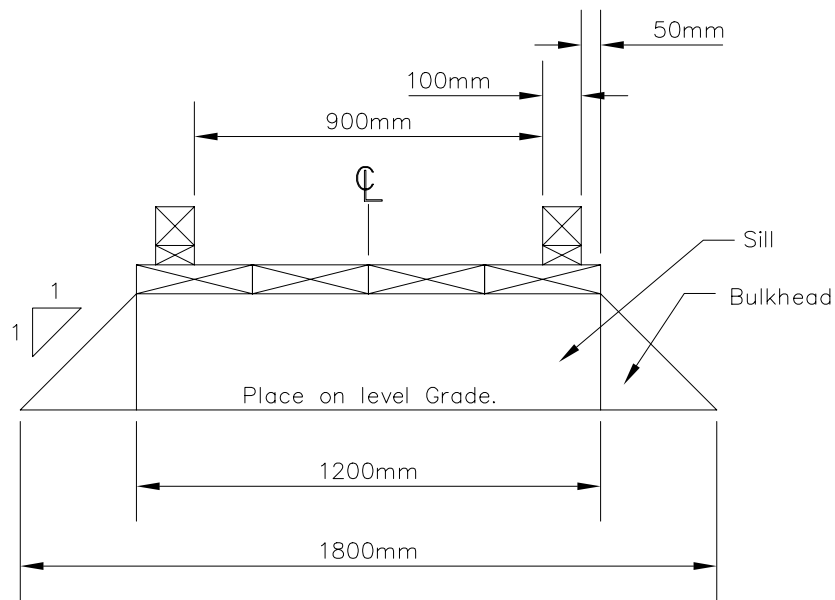

SECTION A-A

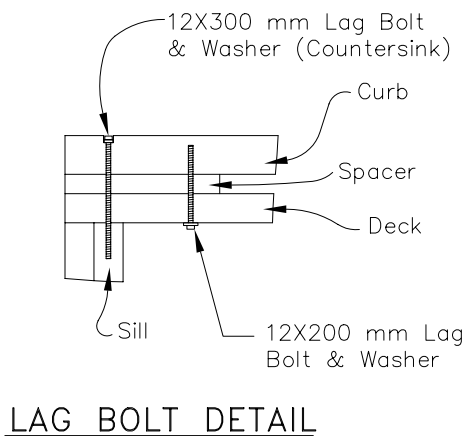

LAG BOLT DETAIL

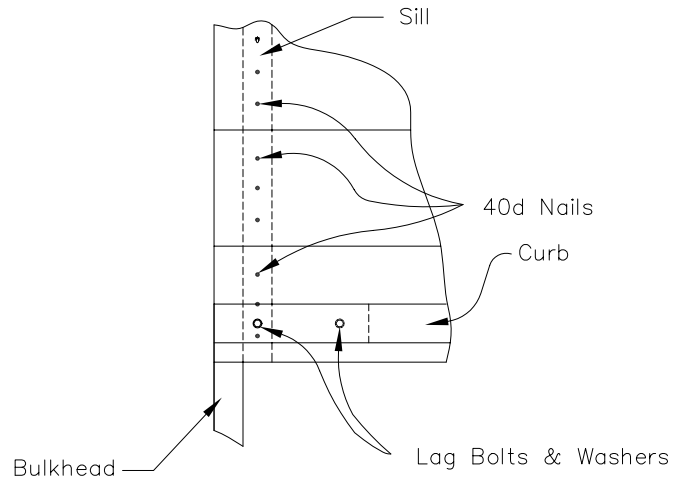

NAILING DETAIL

NAILING PATTERN:

Sill To Bulkhead - 30d nails in two 150 mm staggered rows, 50 mm minimum from edges of sills.
Deck To Sill - Three 40d nails through each deck plank into sills, on both ends of plank, 50 mm minimum from sides of deck.

PRESERVATIVE TREATMENT:

_____ Net Retention _____ kg/m³
 Lumber rough sawn except as noted.